



High Efficiency, 40 V Input, 1 A, Sync DC-DC BUCK Converter

Description

ME3121 is a sync BUCK DC-DC converter IC, which integrates two NMOSFET power switches with low on-resistance. And $R_{DS(ON)}$ of high side and low side switches are 170mΩ and 410mΩ respectively. This product is capable of delivering 1A load current. In light load condition, ME3121 works in the PFM mode which has good efficiency performance. When load current goes heavy, ME3121 works in a quasi PWM mode. At this time, it has a constant switching frequency of 1 MHz. ME3121 incorporates OTP, input UVLO, cycle by cycle current limit protection and output short circuit protection to improve reliability.

Features

- Input Voltage Range: 4.7V ~ 40V
- Shutdown Current: 8uA
- Quiescent Current: 120uA
- $R_{DS(ON)}$ (LSD/HSD): 170mΩ/410mΩ
- Switching Frequency: 1MHz
- Reference Voltage: 0.6V ± 2%
- Cycle by Cycle Peak Current Limit: 1.9A
- Short Circuit Protection: Hiccup Mode
- Overtemperature Protection: 160°C

Applications

- Set Top Box
- LCD TV
- DSL Modem
- Digital TV

Package

- 6-pin SOT23-6

Typical Application Circuit

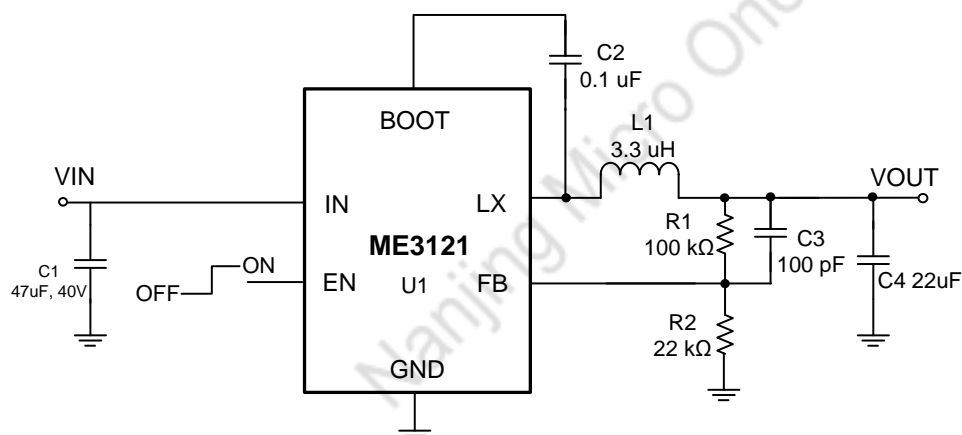

Selection Guide

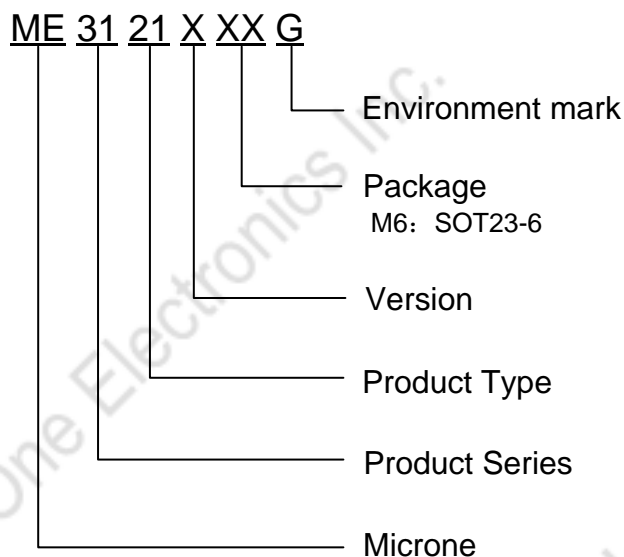

product series	product description
ME3121AM6G	Package: SOT23-6

Pin Configuration

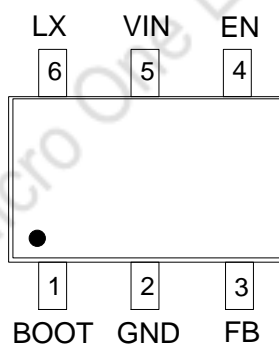

SOT23-6

Pin Assignment

Pin Number	Pin name	Function
1	BOOT	A ceramic capacitor more than 0.1 uF is needed between BOOT and LX. Power supply for driver of high side switch.
2	GND	Ground pin.
3	FB	Feedback voltage pin. Inverting input port of error amplifier.
4	EN	Enable input pin. High logic enables the IC.
5	VIN	Power input pin. Power supply for controller and switches.
6	LX	Switch node and connecting inductor.

Block Diagram

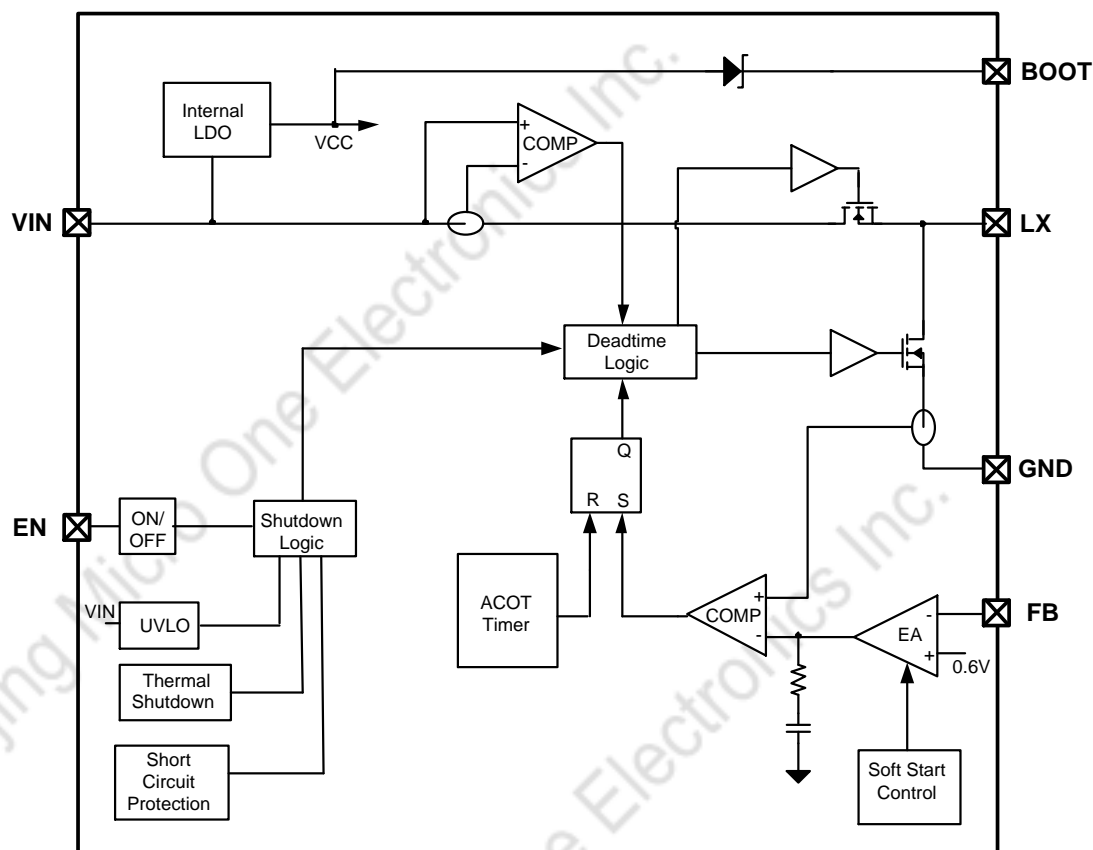

Absolute Maximum Ratings

Parameter	Symbol	Ratings	Unit
VIN pin voltage range	V_{IN}	-0.3 ~ 40	V
LX pin voltage range	V_{LX}	-0.3 (-6.5V<5ns) ~ 40	V
voltage between BOOT pin and LX pin	V_{BOOT_LX}	-0.3 ~ 6	V
EN pin voltage range	V_{EN}	-0.3 ~ 40	V
FB pin voltage range	V_{FB}	-0.3 ~ 40	V
Internal Power Dissipation	P_d	0.63	W
Thermal resistance (Junction to air)	θ_{JA}	200	°C/W
Operating Temperature Range	T_A	-40 ~ +85	°C
Storage Temperature Range	T_{STG}	-55 ~ +150	°C
Maximum junction temperature	T_J	-40 ~ +150	°C

Attention: Stresses beyond those listed under **Absolute Maximum Ratings** may cause permanent damage to the device

Recommended Operating Conditions

Symbol	Description	Min	Typ	Max	Unit
V_{IN}	Input voltage	4.7	12	40	V
V_{OUT}	Output voltage	0.6	3.3	12	V
L	Inductor value	1.2	3.3	6	μ H
C_{OUT}	Output capacitor	10	20	-	μ F
T_A	Operating ambient temperature	-40	-	85	$^{\circ}$ C

Electrical Characteristic

ME3121 test conditions: $V_{IN} = 12$ V, $V_{OUT} = 3.3$ V, $T_A = 25^{\circ}$ C, unless otherwise noted.

Parameter	Symbol	Condition	Min	Typ	Max	Unit
Input voltage range	V_{IN}		4.7	-	40	V
Shutdown current	I_{SD}	$V_{IN} = 40$ V, IC is enabled.	-	8	15	μ A
Quiescent current	I_Q	$V_{IN} = 40$ V, $V_{FB} = 0.66$ V, IC is enabled	-	120	200	μ A
Feedback reference voltage	V_{REF}		0.588	0.6	0.612	V
High side on-resistance	R_{DSON_H}	$V_{BOOT} - V_{LX} = 4.3$ V	-	410	500	m Ω
Low side on-resistance	R_{DSON_L}		-	170	210	m Ω
Peak current limit	I_{LIM_PEAK}		-	1.9	2.5	A
Valley current limit	I_{LIM_VALLEY}		-	1.4	1.9	A
EN rising threshold	V_{ENH}	V_{EN} rises.	-	1.3	1.5	V
EN falling threshold	V_{ENL}		0.8	1	-	V
Input UVLO threshold	V_{IN_UVLO}	V_{IN} falls	-	4.55	4.7	V
Input UVLO hysteresis	V_{IN_HYS}		-	0.2	-	V
Minimum on time	T_{min_on}		-	100	150	ns
Minimum off time	T_{min_off}		-	150	200	ns
Switching frequency	F_{LX}		-	1	-	MHz
Soft startup time	t_{ss}		-	2.3	-	ms
Over temperature protection	T_{OTP}		-	160	-	$^{\circ}$ C
Over temperature protection hysteresis	T_{HYS}		-	40	-	$^{\circ}$ C

Typical Performance Characteristics

Efficiency vs. I_{OUT}

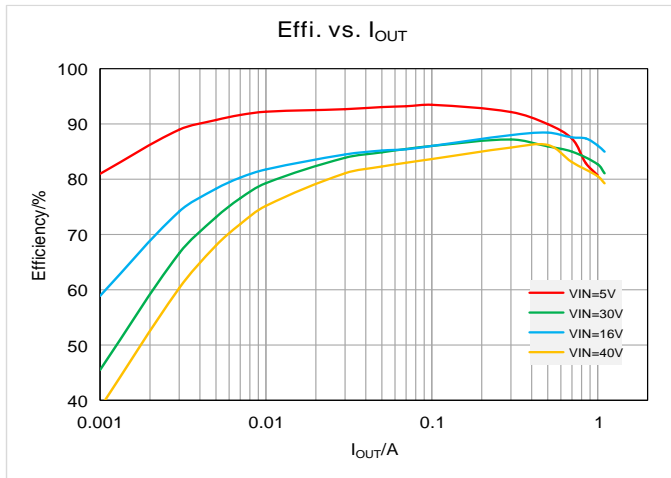

Reference Voltage vs. Temp.

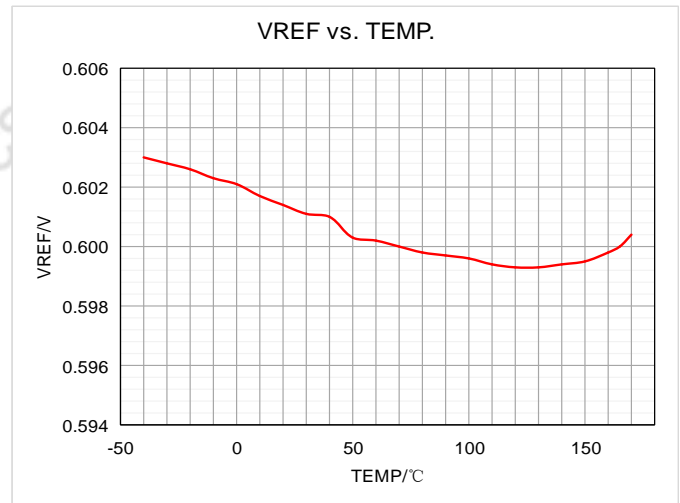

Soft Startup (V_{IN}=40V, V_{OUT}=3.3V, I_{OUT}=1A)

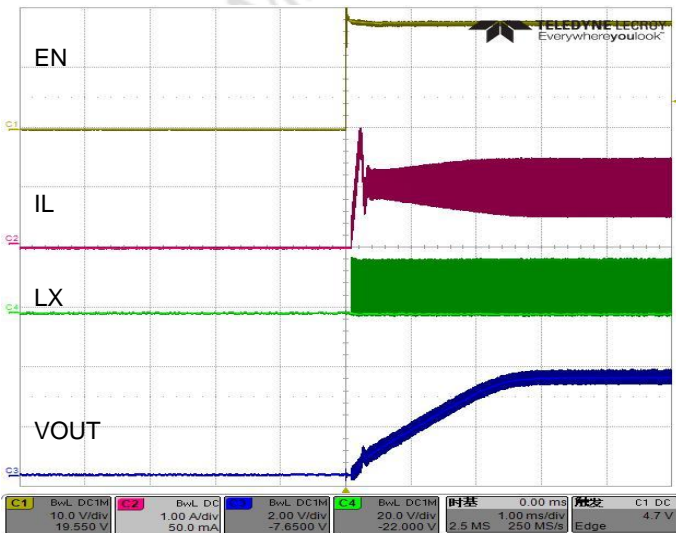

Shutdown

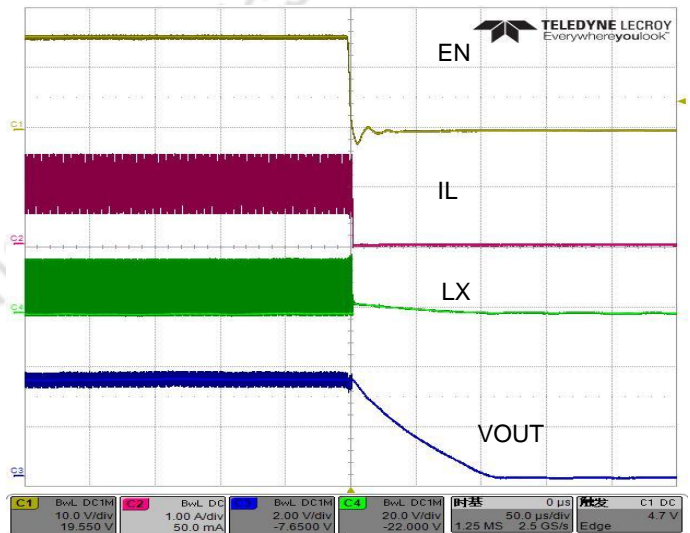

Switching Waveform

(V_{IN}=18V, V_{OUT}=3.3V, I_{OUT}=0.2A)

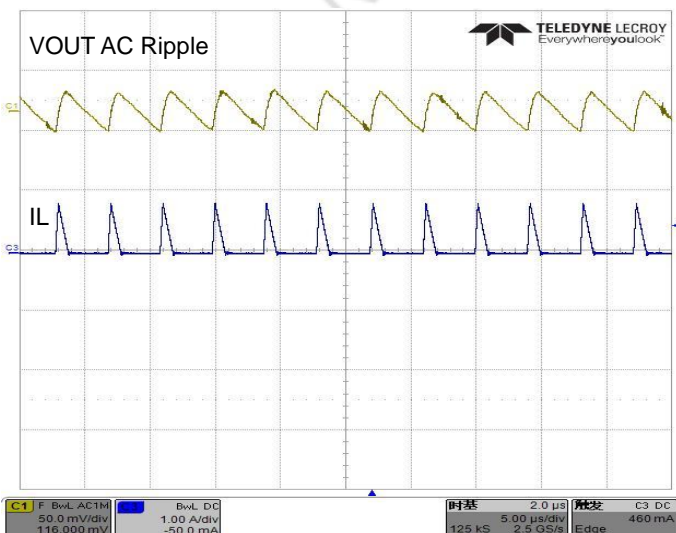

Switching Waveform

(V_{IN}=18V, V_{OUT}=3.3V, I_{OUT}=1A)

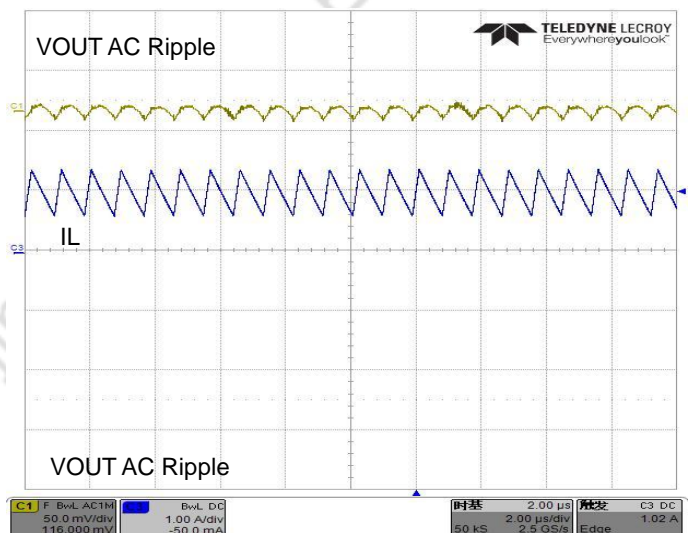

Load Transient Response

($V_{IN}=18V, V_{OUT}=3.3V, I_{OUT}=0.1A-1A$)

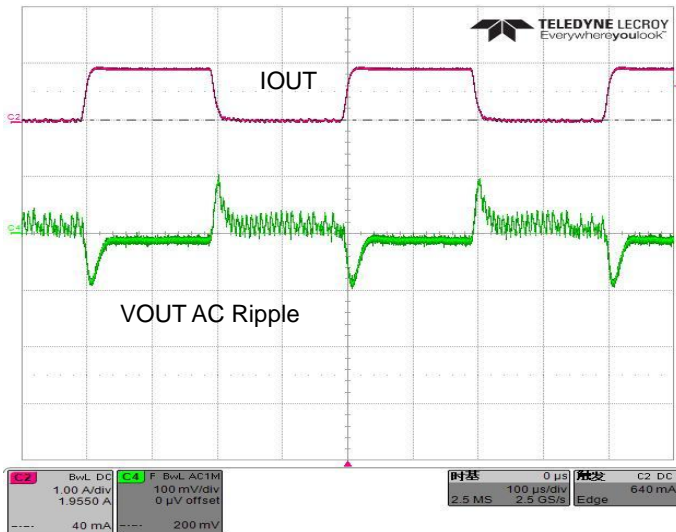

Short Circuit Protection and Recovery

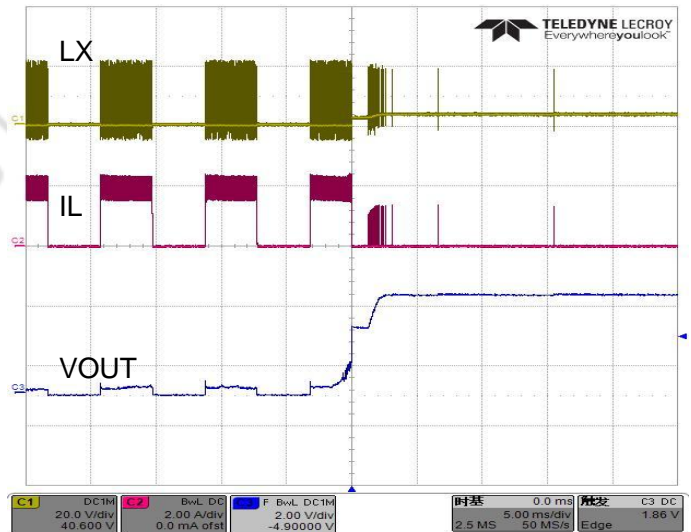

Operation

ME3121 is a highly efficient sync BUCK converter integrated circuits. It integrates two NMOSFET power switches of low on resistance. Power of driver of high side switch is supplied by bootstrap capacitor. The input voltage reaches up to 40V. This converter can deliver 1A output current. ME3121 adopts constant on time architecture and has fast load transient response. In light load condition, it works in the PFM mode. In heavy load condition, it works in the quasi PWM mode.

Soft Startup

When the EN pin is pulled high, the blocks in the IC start to work in order. After the 0.6 V reference voltage settles down, a small current charges the soft startup capacitor. And the voltage of soft startup capacitor is used to control error amplifier. During the soft startup phase of about 2.3 ms, the soft startup voltage rises to 0.6 V gradually and V_{OUT} ramps up to the setting point accordingly. Soft startup can avoid large inrush current and V_{OUT} overshoot.

PFM Mode

When the load current decreases from heavy load, inductor current is reduced accordingly. And if the inductor valley current touches zero level, the device works in the DCM. Each switching period starts with charging inductor with constant time. Then the output voltage rises to a higher level. After the constant on time, the high side switch cuts off and the inductor current discharges to zero level. Because of the smaller load current, it takes longer time to discharge the output voltage to the reference level. And the switching frequency is reduced, proportional to the load current.

Shot Circuit Protection

When output is short to the ground, the device will shutdown for about 3.5ms. Then the chip can resume soft

startup automatically. After it maintains working for about 3ms, the device will stop from switching again. The device will repeat to shutdown and resume soft startup until the output short condition is released. Then output voltage will softly start up to the setting value..

Application Information

ME3121 can be used in applications in which power supply is converted from high level to low level. Because of the integrated power switches in IC, only input capacitor C_{IN} , output inductor L, output capacitor C_{OUT} and feedback resistors are selected for the desired application.

Setting Output Voltage

The output voltage can be set by selecting proper feedback resistors R1 and R2. To achieve good noise and power performance, it's recommended to using resistors between 10kΩ and 1 MΩ. The resistor R1 can be calculated by the following equation.

$$R_1 = R_2 \times \left(\frac{V_{OUT}}{0.6V} - 1 \right)$$

Inductor Selection

To guarantee the normal work of the power system, the output inductor peak current should be below the peak current limit of 1.9A. The inductor peak current can be calculated by the following equation. In consideration of magnetic saturation of inductor, the peak current should be also smaller than the saturate current of the inductor. And low DCR can help to meet desired power efficiency requirement.

$$I_{PEAK} = I_{OUT} + \frac{V_{OUT} \times (V_{IN} - V_{OUT})}{2 \times V_{IN} \times L} \times T$$

Bootstrap Capacitor

A 0.1uF ceramic capacitor connected between the LX pin and the BOOT pin is required to supply power for the high side switch in applications based on ME3121.

Input Capacitor

In the BUCK converter system, severe interference exists between the VIN pin and ground. The input capacitor C_{IN} can help to reduce interference and improve system stability. Because the effective capacitance can be reduced significantly at the DC biasing voltage, so the rated voltage of input capacitor should exceed the highest input voltage. And recommends the input capacitor should be placed as closely as possible to the VIN pin of the ME3121.

Output Capacitor

The step down DC-DC converter needs output filter capacitor. Small output capacitor may result in system instability. When output short circuit condition is released, the output voltage may overshoot the safe level, which can damage the following devices permanently.

Layout Guidelines

- 1) BUCK converter implemented by ME3121 is sensitive to PCB layout. For reducing nonideality, external components such as inductor, input capacitor, output capacitor and resistor divider should be placed as nearly as possible to the chip.
- 2) For reducing EMI caused by high frequency switching, the trace connected to LX pin should be as short as possible. It is recommended to use ground plane to shield signal from interplane coupling.
- 3) To improve thermal dissipation and power efficiency, it is recommended to cover the back of PCB with ground plane. More thermal vias and thick PCB copper are desirable.

Package Quantity

Package Type	Minimum Packing QTY	UNITS	Small Box	Large BOX
SOT23-6	3000	Tape & Reel	30K	120K

Package Information

- Package Type: SOT23-6

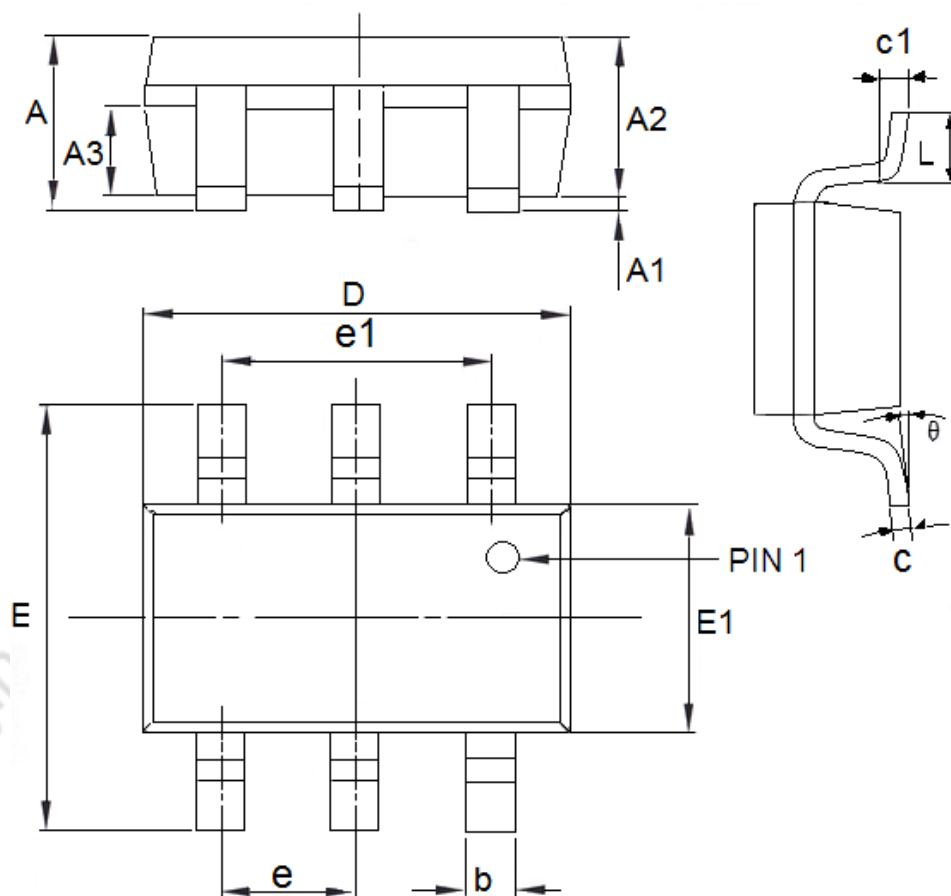

DIM	Millimeters		Inches	
	Min	Max	Min	Max
A	1.05	1.45	0.0413	0.0571
A1	0	0.15	0.0000	0.0059
A2	0.9	1.3	0.0354	0.0512
A3	0.55	0.75	0.0217	0.0295
b	0.25	0.5	0.0098	0.0197
c	0.1	0.25	0.0039	0.0098
D	2.7	3.12	0.1063	0.1228
e1	1.9(TYP)		0.0748(TYP)	
E	2.6	3.1	0.1024	0.1220
E1	1.4	1.8	0.0551	0.0709
e	0.95(TYP)		0.0374(TYP)	
L	0.25	0.6	0.0098	0.0236
θ	0	8°	0.0000	8°
c1	0.2(TYP)		0.0079(TYP)	

- The contents of this document will be updated with the product's improvement without prior notice. Please consult our sales staff before using this document to ensure that you are using the latest version.
- The application circuit examples described in this document are only used to indicate the representative use of the product and do not guarantee the design of mass production.
- Please use this product within the limits stated in this document. We will not be responsible for any damage caused by improper use.
- The products described in this document are not allowed to be used in equipment or devices that affect the human body without the written permission of our company, including but not limited to: health equipment, medical equipment, disaster prevention equipment, fuel control equipment, automobile equipment, aviation equipment and vehicle equipment.
- Although our company has always been committed to improving product quality and reliability, semiconductor products have a certain probability of malfunction or wrong work. To prevent personal injury or property damage caused by such accidents, please pay full attention to safety design, for example: Alternate design, fire protection design, and prevention of wrong action design.
- When exporting this product or this document overseas, you should abide by applicable import and export control laws.
- Copying or reprinting part or all of this document in any form without the permission of our company is strictly prohibited.