



Adjustable Precision Shunt Regulator

General Description

The ME431 series ICs are three-terminal adjustable shunt regulators with guaranteed thermal stability over a full operation range. These ICs feature sharp turn-on characteristics, low temperature coefficient and low output impedance, which make them ideal substitutes for Zener diodes in applications such as switching power supply, charger and other adjustable regulators.

The ME431 voltage type is 40V. The output voltage can be set to any value between V_{REF} (2.5V) and the corresponding maximum cathode voltage.

The ME431 precision reference is offered in three band gap tolerance: $\pm 0.2\%$ 、 $\pm 0.4\%$ and $\pm 1.0\%$.

Typical Application

- Charger
- Voltage Adapter
- Switching Power Supply
- Graphic Card
- Precision Voltage Reference

Features

- Programmable Precise Output Voltage from 2.5V to 36V
- Very Accurate Reference Voltage: Typical 0.15%
- High Stability under Capacitive Load
- Low Temperature Deviation: Typical 4.5mV
- Low Equivalent Full-range Temperature Coefficient with 20PPM/°C Typical
- Low Dynamic Output Resistance: Typical 0.2Ω
- Sink Current Capacity from 1mA to 100 mA
- Low Output Noise
- Wide Operating Range of -40 to 85°C

Package

- 3-pin SOT23、TO92、SOT89-3

Selection Guide

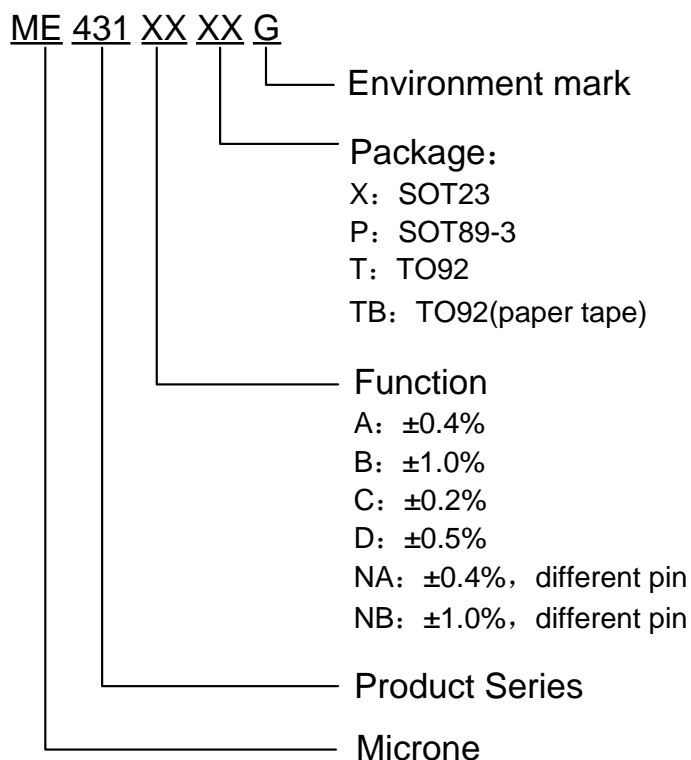

product series	product description
ME431AXG	$V_{REF}=2.5V\pm 0.4\%$; Package: SOT23
ME431BXG	$V_{REF}=2.5V\pm 1.0\%$; Package: SOT23
ME431CXG	$V_{REF}=2.5V\pm 0.2\%$; Package: SOT23
ME431DXG	$V_{REF}=2.55V\pm 0.5\%$; Package: SOT23
ME431APG	$V_{REF}=2.5V\pm 0.4\%$; Package: SOT89-3
ME431ATG	$V_{REF}=2.5V\pm 0.4\%$; Package: TO92
ME431BTG	$V_{REF}=2.5V\pm 1.0\%$; Package: TO92
ME431ATBG	$V_{REF}=2.5V\pm 0.4\%$; Package: TO92; paper tape
ME431BTBG	$V_{REF}=2.5V\pm 1.0\%$; Package: TO92; paper tape
ME431NAXG	$V_{REF}=2.5V\pm 0.4\%$; Package: SOT23; Different pin
ME431NBXG	$V_{REF}=2.5V\pm 1.0\%$; Package: SOT23; Different pin

NOTE: If you need other voltage and package, please contact our sales staff.

PIN Configuration

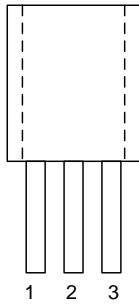

TO92

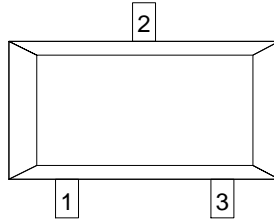

SOT23

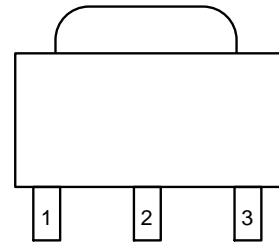

SOT89-3

Pin Assignment

Pin Number		Symbol	Functions
ME431	ME431N		
1	3	R	reference
2	2	A	anode
3	1	K	cathode

Block Diagram and symbol

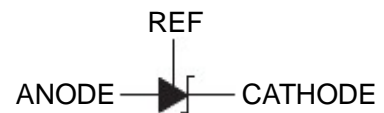
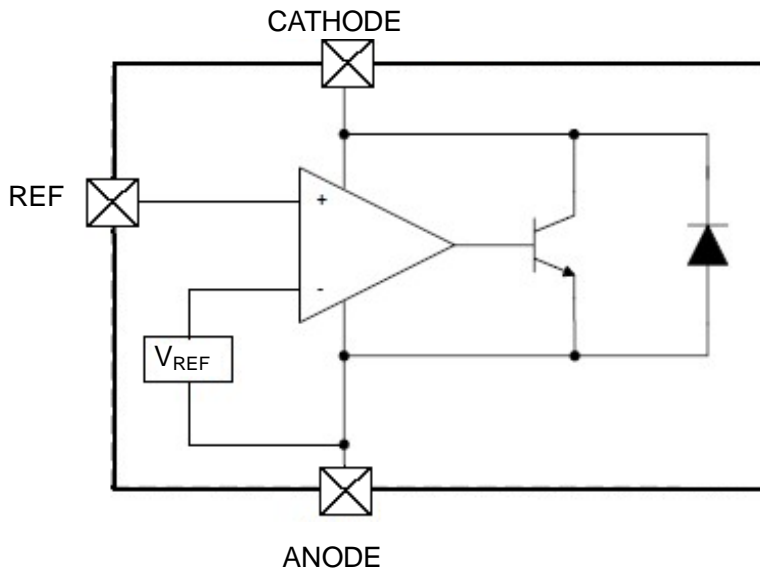

Absolute Maximum Ratings

Parameter	Symbol	Rating	Unit
Cathode voltage	V_{KA}	40	V
Cathode current range (continuous)	I_{KA}	-100~+130	mA
Reference input current range	I_{REF}	10	mA
Power Dissipation	P_D	TO-92 Package: 0.8	W
		SOT23 Package:0.4	
		SOT89-3 Package:1.25	
Junction temperature	T_J	-40~+150	°C
Storage Temperature range	T_{STG}	-55~+150	°C
Package thermal impedance (Junction to air)	θ_{JA}	TO-92 package:150	°C/W
		SOT23 package:330	
		SOT89-3 Package:100	

Note: Use this IC within the stated maximum ratings. Operation beyond these limits may cause degrading or permanent damage to the device.

Recommended Operating Conditions

Parameter	Symbol	Min	Max	Unit
Cathode Voltage	V_{KA}	V_{REF}	36	V
Cathode Current	I_{KA}	1.0	100	mA
Operating Ambient Temperature Range		-40	85	°C

Electrical Characteristics ($T_A=25^\circ\text{C}$, unless otherwise noted)

Parameter	Symbol	Conditions	Min	Typ.	Max	Unit	Test circuit	
Reference voltage	V_{REF}	$V_{KA}=V_{REF}, I_{KA}=10\text{mA}$	2.495	2.50	2.505	V	Fig.1	
			2.490	2.50	2.510			
			2.475	2.50	2.525			
			2.537	2.55	2.562			
Deviation of reference voltage over-temperature	ΔV_{REF}	$V_{KA}=V_{REF}, I_{KA}=10\text{mA}$	0 to 70°C	-	7	10	mV	Fig.1
			-40 to 150°C	-	25	30		
Dynamic impedance	$ Z_{KA} $	$V_{KA}=V_{REF}, I_{KA}=1$ to 100mA, $f \leq 1.0\text{KHz}$	-	0.15	0.5	Ω	Fig.1	
Minimum cathode current for regulation	$I_{KA}(\text{MIN})$	$V_{KA}=V_{REF}$	-	0.4	1.0	mA	Fig.1	
Ratio of change in reference voltage to the change in cathode voltage	$\frac{\Delta V_{REF}}{\Delta V_{KA}}$	$I_{KA}=10\text{mA}$	$\Delta V_{KA} = 10\text{V}$ to V_{REF}	-	-0.8	-2.5	mV/V	Fig.2
			$\Delta V_{KA} = 36\text{V}$ to 10V	-	-0.6	-1.5		

Reference current	I_{REF}	$I_{KA}=10mA, R1=10K\Omega, R2=\infty$	0.7	3	μA	Fig.2
Deviation of reference over full temperature range	ΔI_{REF}	$I_{KA}=10mA, R1=10K\Omega, R2=\infty, T_A=40 \text{ to } 150^\circ C$	0.1	1.2	μA	Fig.2
Off-state cathode current	$I_{KA} \text{ (OFF)}$	$V_{KA}=36V, V_{REF}=0$	0.03	0.3	μA	Fig.3

Note: The dynamic impedance is defined as: $|Z_{KA}| = \Delta V_{KA} / \Delta I_{KA}$

Test Circuit

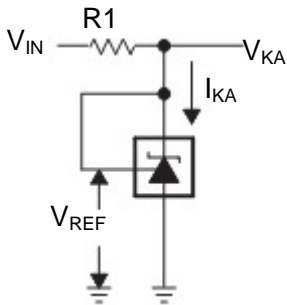
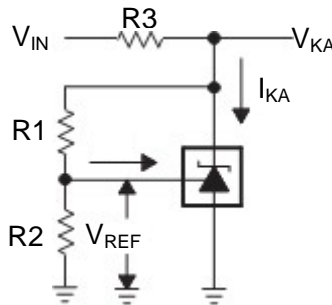

Fig.1: for $V_{KA} = V_{REF}$



$$V_{KA} = V_{REF} (1 + R1/R2) + I_{REF} R1$$

Fig.2: for $V_{KA} > V_{REF}$

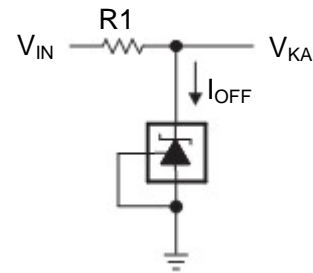
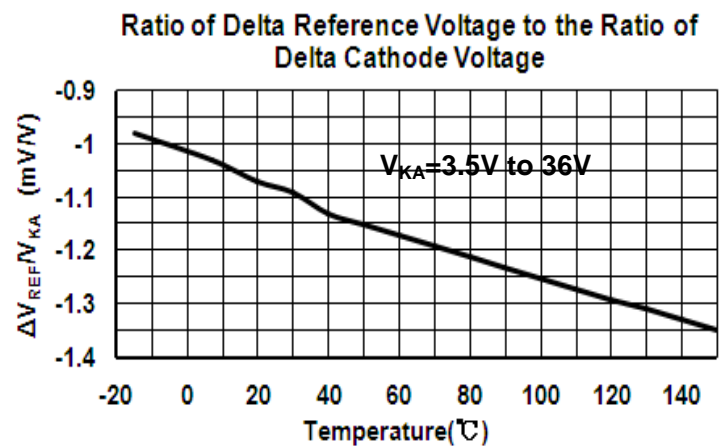
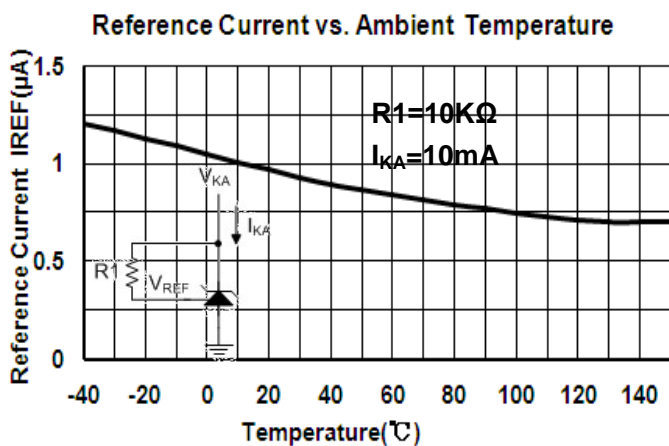
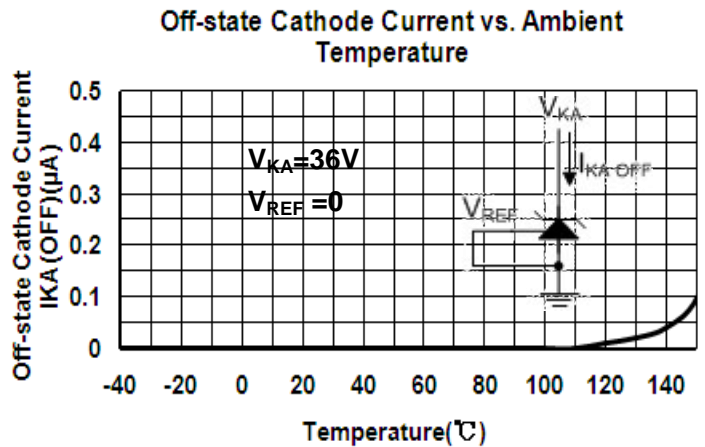
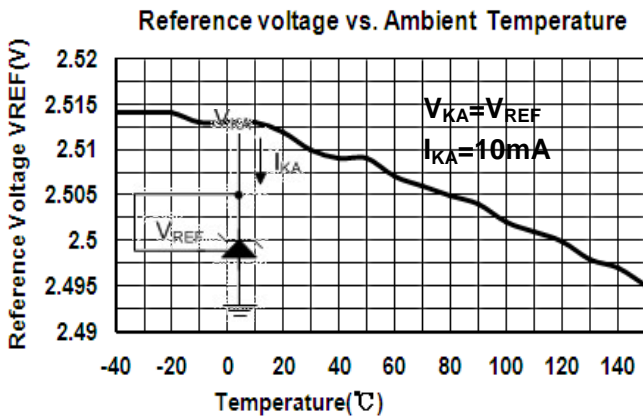
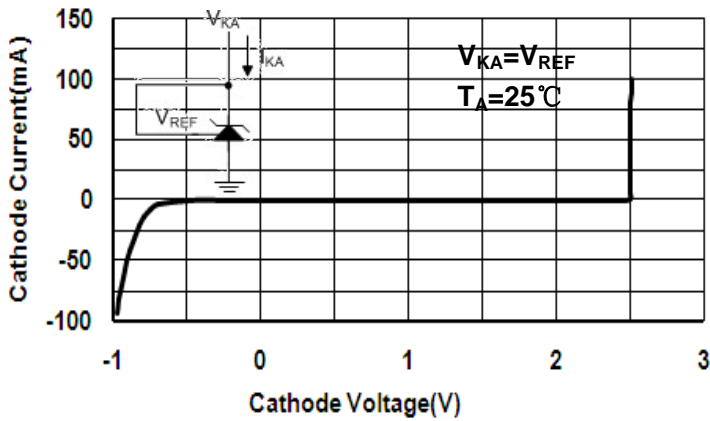

Fig.3: for I_{OFF}

Typical Performance Characteristics



Cathode Current vs. Cathode Voltage



Cathode Current vs. Cathode Voltage

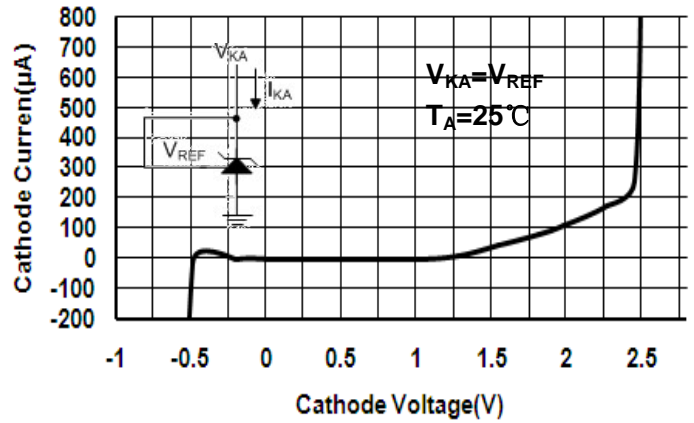

Small Signal Voltage Gain vs. Frequency

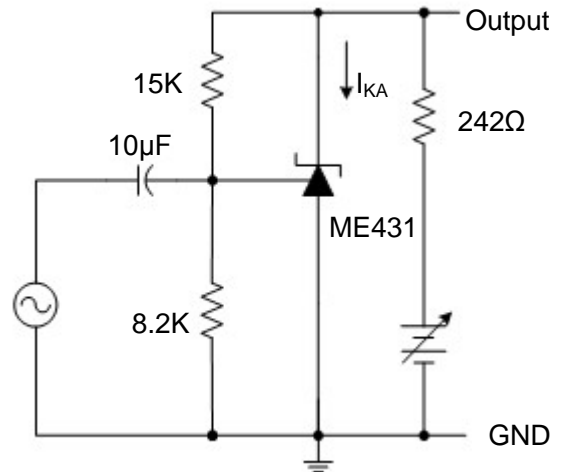
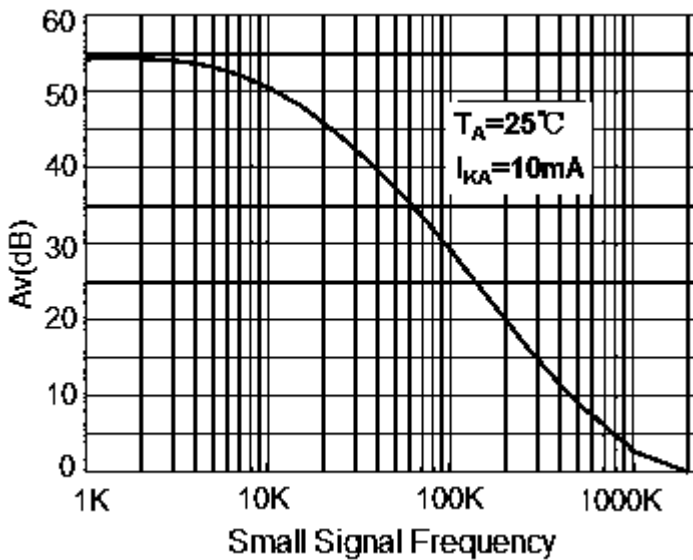

Reference Impedance vs. Frequency

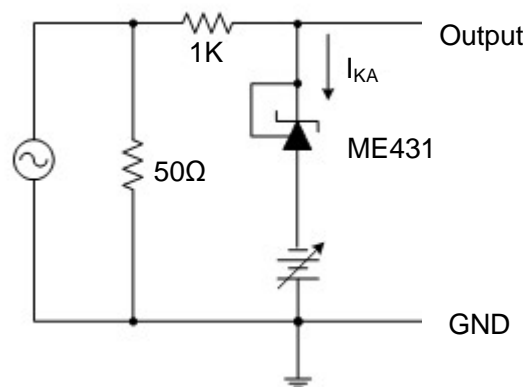
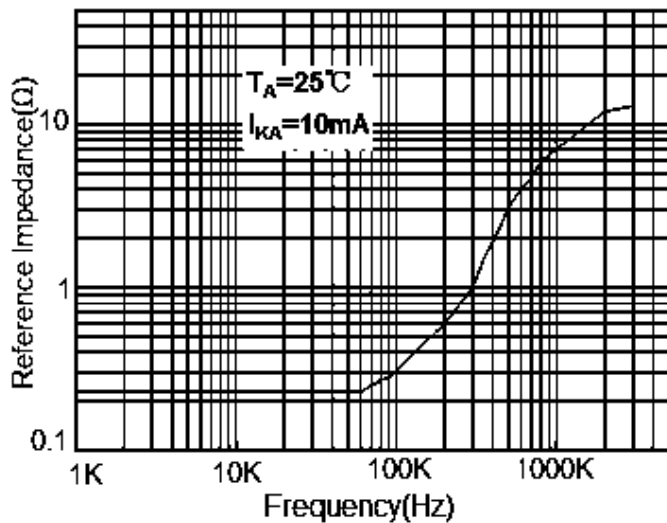

Stability Boundary Conditions vs. Load Capacitance

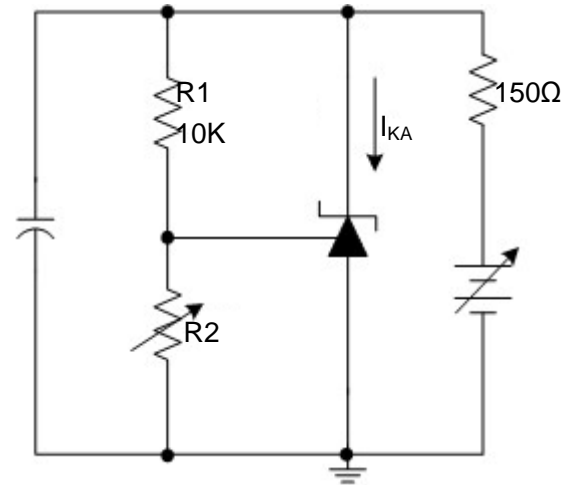
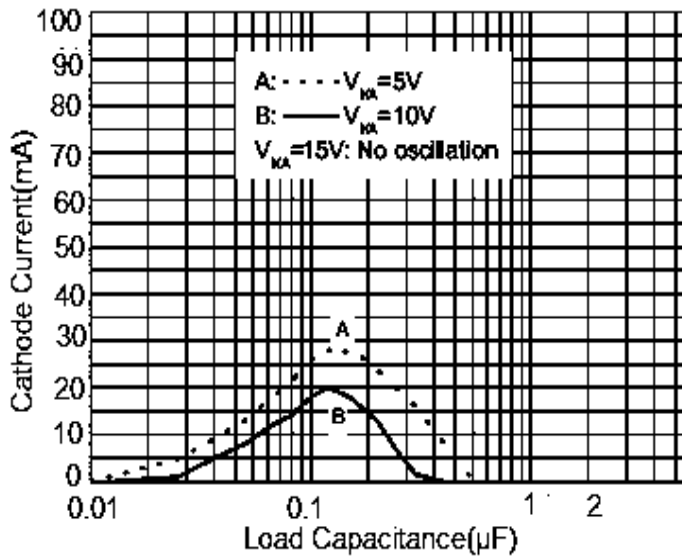

Pulse Response of Input and Output Voltage

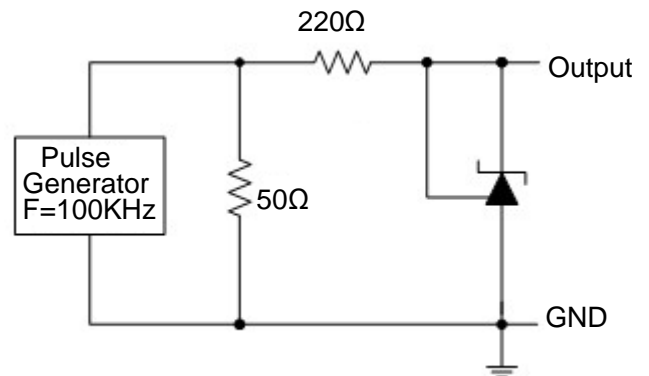
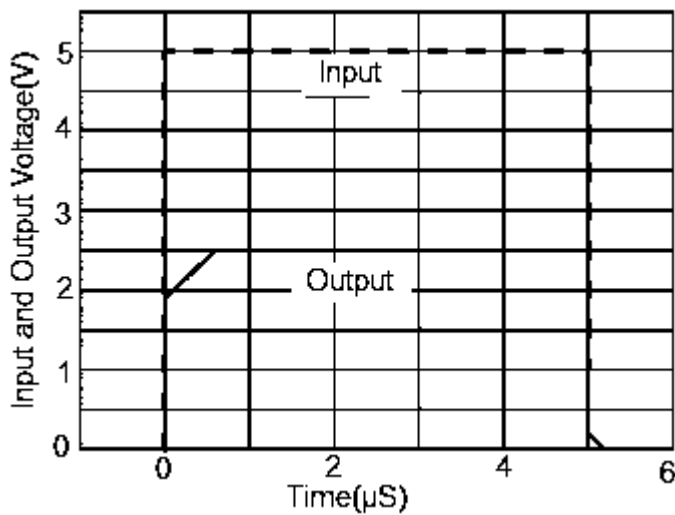

Typical Application

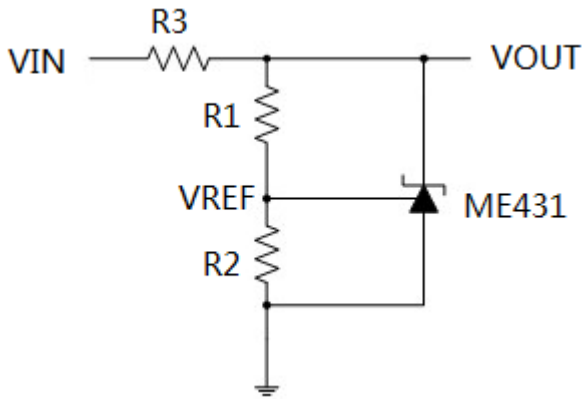

$$V_O = (1 + R1/R2)V_{REF}$$

Fig.4: Shunt Regulator

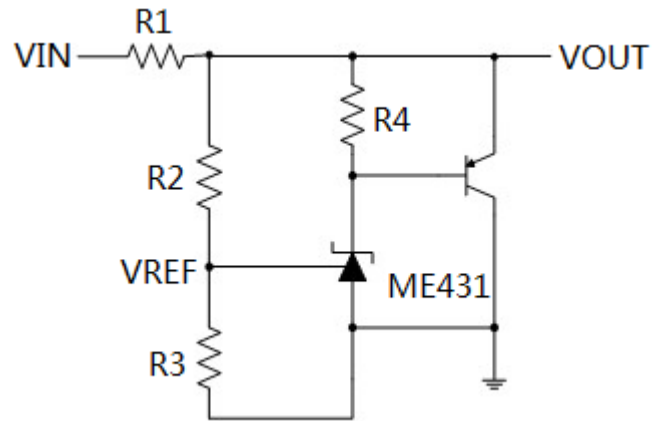

$$V_O = (1 + R2/R3)V_{REF}$$

Fig.5: High Current Shunt Regulator

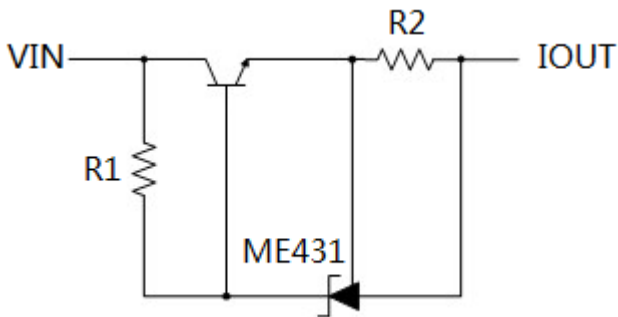

$$I_{OUT} = V_{REF}/R2 + I_{KA}$$

Fig.6: Current Source or Current Limit

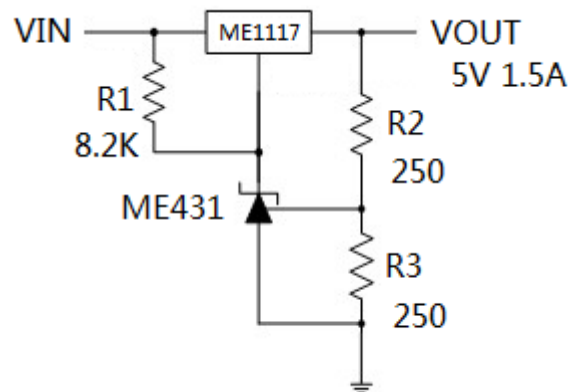
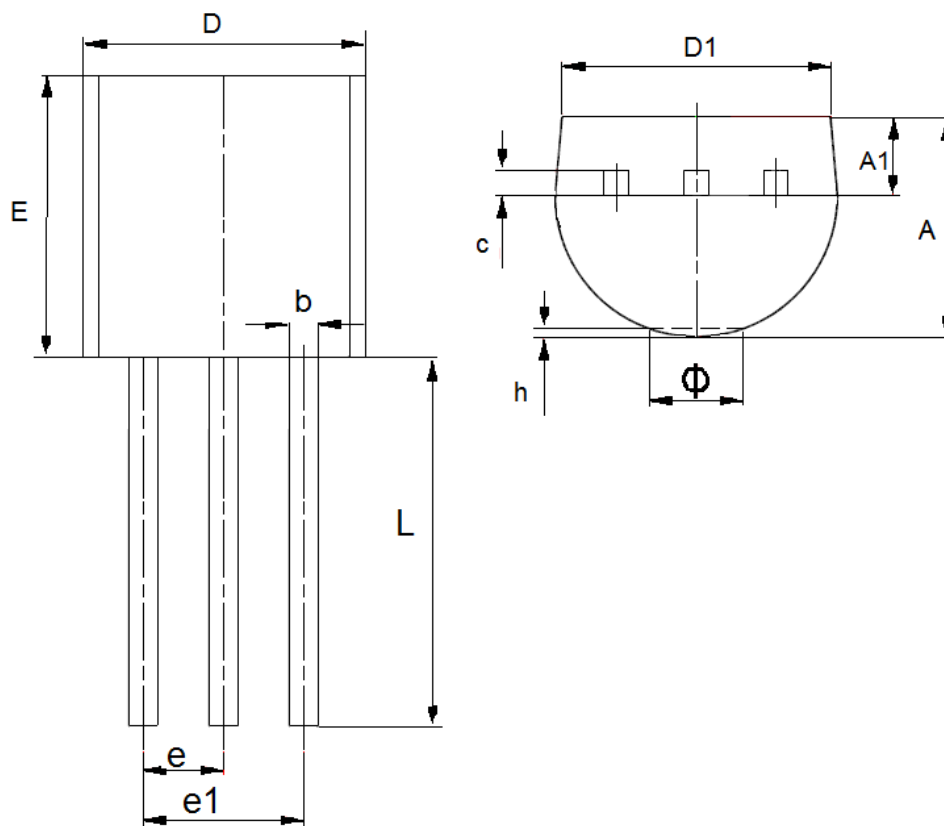

Fig.7: Precision 5V 1.5A Regulator

Packaging Type

- TO-92



DIM	Millimeters		Inches	
	Min	Max	Min	Max
A	3.3	3.7	0.1299	0.1457
A1	1.1	1.4	0.0433	0.0551
b	0.38	0.55	0.015	0.0217
c	0.36	0.51	0.0142	0.0201
D	4.3	4.7	0.1693	0.185
D1	3.43	—	0.135	—
E	4.3	4.7	0.1693	0.185
e	1.27TYP		0.05TYP	
e1	2.44	2.64	0.0961	0.1039
L	14.1	14.5	0.5551	0.5709
h	0	0.38	0	0.015
Φ	—	1.6	—	0.063

● TO-92 (Paper Tape)

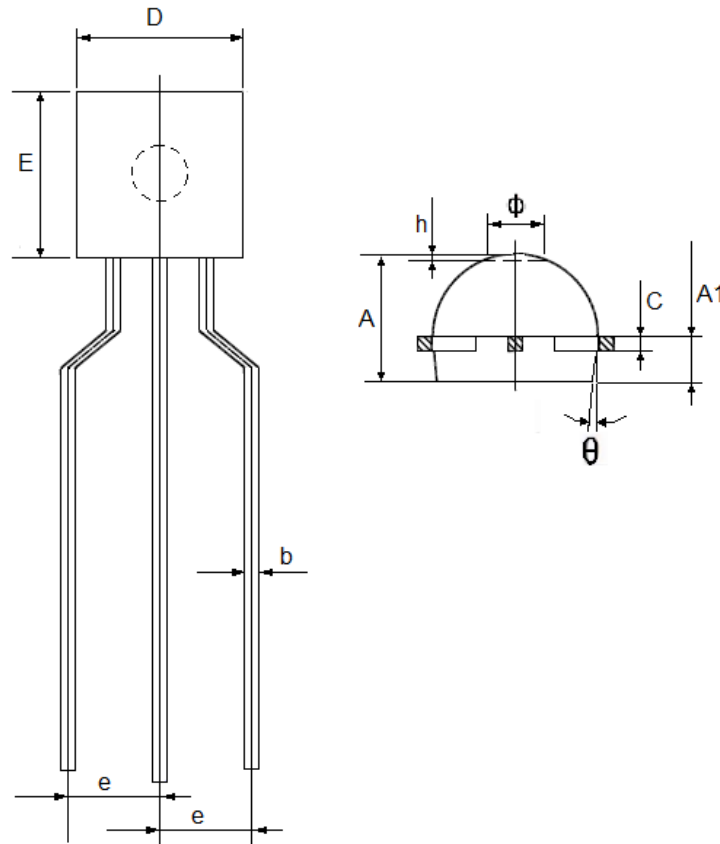

DIM	Millimeters		Inches	
	Min	Max	Min	Max
A	3.4	3.7	0.1339	0.1457
A1	1.15	1.4	0.0453	0.0551
b	0.36	0.5	0.0142	0.0197
c	0.38		0.0150	
D	4.4	4.7	0.1732	0.1850
E	4.4	4.7	0.1732	0.1850
e	2.2	2.8	0.0866	0.1102
Φ	1.5		0.0591	
θ	5°		5°	
h	0.2		0.0079	

● SOT23

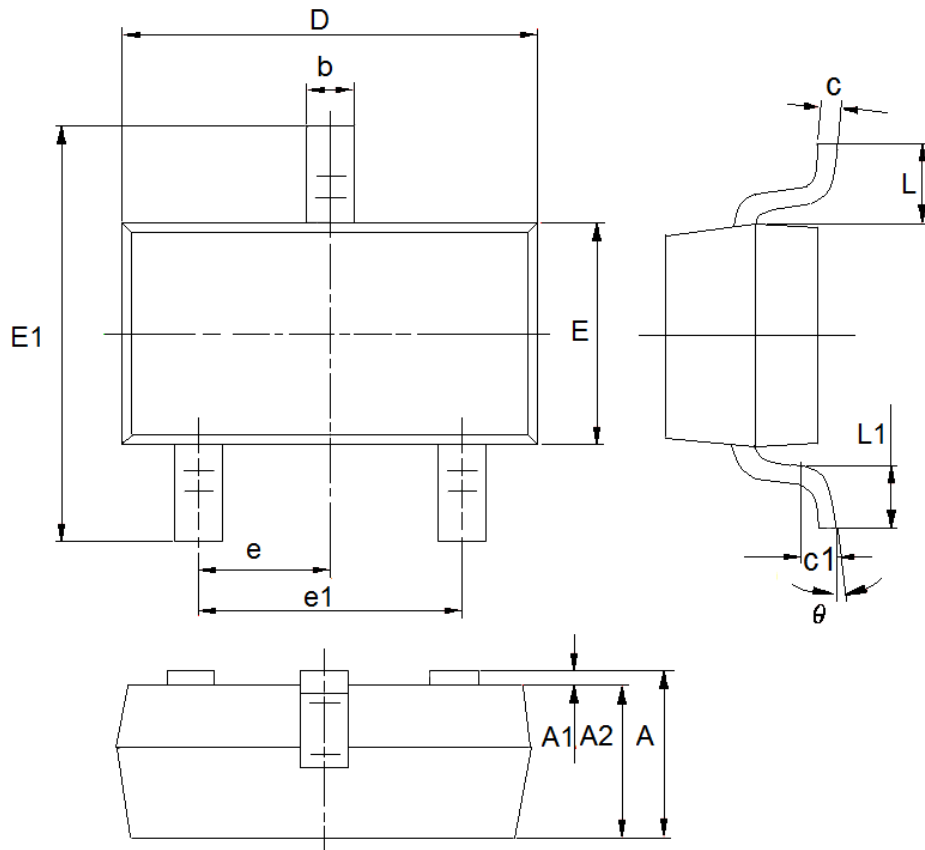

DIM	Millimeters		Inches	
	Min	Max	Min	Max
A	0.9	1.15	0.0354	0.0453
A1	0	0.14	0.0000	0.0055
A2	0.9	1.05	0.0354	0.0413
b	0.28	0.52	0.0110	0.0205
c	0.07	0.23	0.0028	0.0091
D	2.8	3.0	0.1102	0.1181
e1	1.8	2.0	0.0709	0.0787
E	1.2	1.4	0.0472	0.0551
E1	2.2	2.6	0.0866	0.1024
e	0.95(TYP)		0.0374(TYP)	
L	0.55(TYP)		0.0217(TYP)	
L1	0.25	0.55	0.0098	0.0217
θ	0	8°	0.0000	8°
c1	0.25(TYP)		0.0098(TYP)	

● SOT89-3

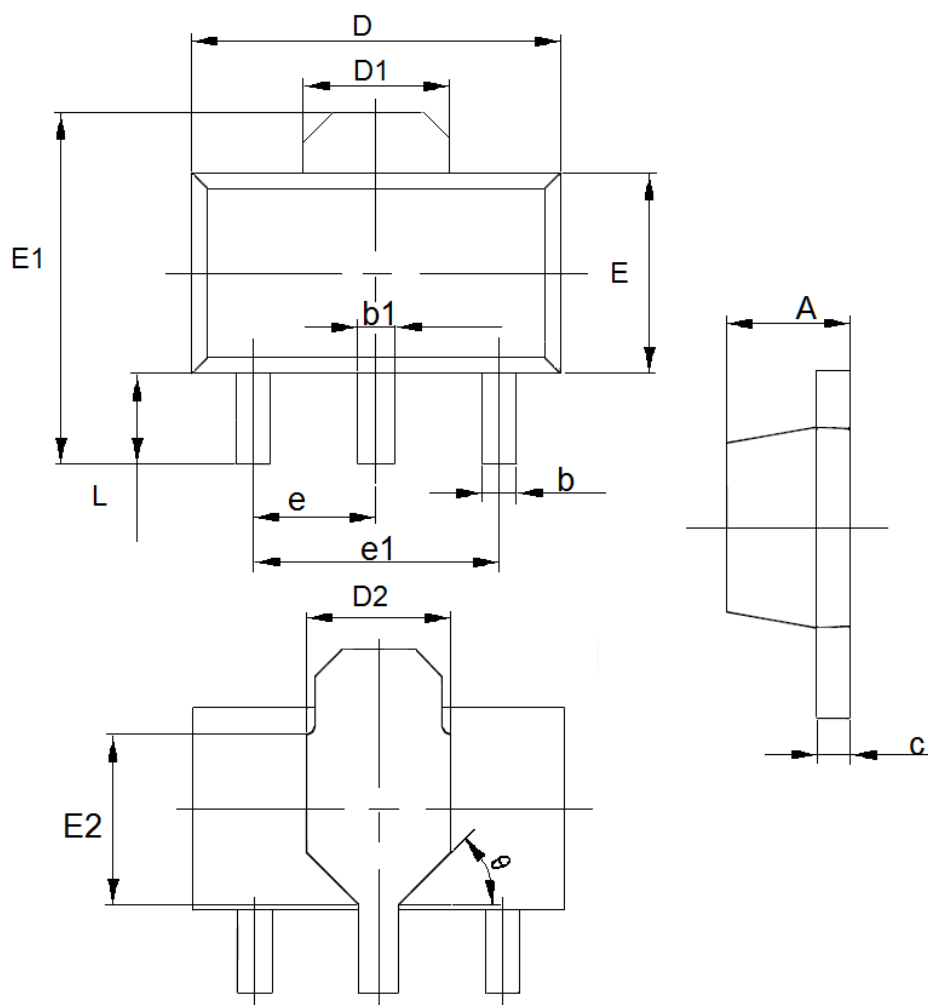

DIM	Millimeters		Inches	
	Min	Max	Min	Max
A	1.4	1.6	0.0551	0.0630
b	0.32	0.52	0.0126	0.0205
b1	0.4	0.58	0.0157	0.0228
c	0.35	0.45	0.0138	0.0177
D	4.4	4.6	0.1732	0.1811
D1	1.55(TYP)		0.061(TYP)	
D2	1.75(TYP)		0.0689(TYP)	
e1	3.0(TYP)		0.1181(TYP)	
E	2.3	2.6	0.0906	0.1023
E1	3.94	4.4	0.1551	0.1732
E2	1.9(TYP)		0.0748(TYP)	
e	1.5(TYP)		0.0591(TYP)	
L	0.8	1.2	0.0315	0.0472
θ	45°		45°	

- The contents of this document will be updated with the product's improvement without prior notice. Please consult our sales staff before using this document to ensure that you are using the latest version.
- The application circuit examples described in this document are only used to indicate the representative use of the product and do not guarantee the design of mass production.
- Please use this product within the limits stated in this document. We will not be responsible for any damage caused by improper use.
- The products described in this document are not allowed to be used in equipment or devices that affect the human body without the written permission of our company, including but not limited to: health equipment, medical equipment, disaster prevention equipment, fuel control equipment, automobile equipment, aviation equipment and vehicle equipment.
- Although our company has always been committed to improving product quality and reliability, semiconductor products have a certain probability of malfunction or wrong work. To prevent personal injury or property damage caused by such accidents, please pay full attention to safety design, for example: Alternate design, fire protection design, and prevention of wrong action design.
- When exporting this product or this document overseas, you should abide by applicable import and export control laws.
- Copying or reprinting part or all of this document in any form without the permission of our company is strictly prohibited.