



Features

- Output voltage ranges: Fixed range of 1.8V, 2.5V, 2.7V, 3.0V, 3.3V, 5.0V type.
- Highly accuracy: $\pm 2\%$
- Low voltage drop: 360mV (typ.), $V_{OUT}=5.0V$ at 400-500mA
- Guaranteed output current: 400-500mA
- Low quiescent current: 5 μ A (typ.)
- Current limiting
- Over-temperature shutdown
- SOT-89, TO-92 Packages

Applications

- Battery powered systems
- Personal Digital Assistants
- Peripheral cards
- PCMCIA cards
- Personal Communication Equipment

General Description

The QN78XX series of positive, linear regulators features low quiescent current (5 μ A typ.) with low dropout voltage, making them ideal for battery applications. These devices are capable of supplying 400- 500mA of output current continuously.

They are available with several fixed output voltages ranging from 1.8V to 5.0V. Although designed primarily

as fixed voltage regulators, these devices can be used with external components to obtain variable voltages and currents.

These rugged devices have Thermal Shutdown and Current Limiting to prevent device failure under the "Worst" of operating conditions.

Selection Table

Part No.	Output Voltage	Tolerance	Package
QN7818	1.8V	$\pm 2\%$	SOT-89 TO-92
QN7825	2.5V		
QN7827	2.7V		
QN7830	3.0V		
QN7833	3.3V		
QN7850	5.0V		

Block Diagram

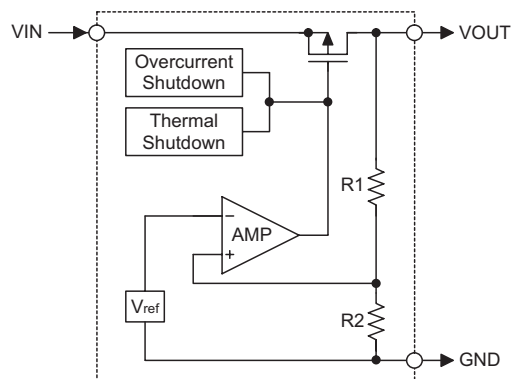

Pin Assignment

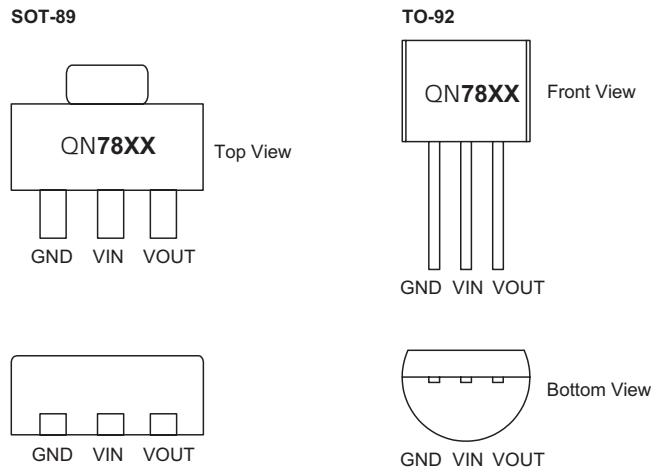

Note: For lead free devices, a # mark is suffixed at the end of the date code.

Absolute Maximum Ratings*

Maximum Supply Voltage up to 8.5V Storage Temperature -50°C to 125°C
 Operating Temperature -40°C to 85°C

Note: These are stress ratings only. Stresses exceeding the range specified under "Absolute Maximum Ratings" may cause substantial damage to the device. Functional operation of this device at other conditions beyond those listed in the specification is not implied and prolonged exposure to extreme conditions may affect device reliability.

"*" Absolute maximum ratings indicate limits beyond which damage to the device may occur. Operating Ratings indicate conditions for which the device is intended to be functional, but do not guarantee specific performance limits. The guaranteed specifications apply only for the test conditions listed.

Symbol	Parameter	Package	Max.	Unit
θ_{JA}	Thermal Resistance (Junction to Ambient) (Assume no ambient airflow, no heat sink)	SOT-89	200	°C/W
		TO-92	200	°C/W
P_D	Power Dissipation	SOT-89	0.50	W
		TO-92	0.50	W

Note: P_D is measured at $T_a = 25^\circ\text{C}$

Electrical Characteristics
 $T_J=25^{\circ}\text{C}$, $V_{IN}=V_{OUT}+1.0\text{V}$, $I_O=1\text{mA}$, unless otherwise specified

Symbol	Parameter	Test Conditions	Min.	Typ.	Max.	Unit	
V_{IN}	Input Voltage	—	—	—	8	V	
ΔV_{OUT}	Output Voltage Tolerance	—	-2	—	2	%	
I_{SS}	Quiescent Current	$I_O=0\text{mA}$	—	5	7	μA	
ΔV_{LOAD}	Load Regulation (Note1)	$1\text{mA} \leq I_{OUT} \leq 500\text{mA}$	—	0.004	0.008	%/mA	
V_{DROP}	Dropout Voltage (Note2)	$\Delta V_{OUT}=2\%$ $I_{OUT}=500\text{mA}$	$V_O \leq 1.8\text{V}$	—	800	1200	mV
			$2.5\text{V} \leq V_O \leq 2.7\text{V}$	—	500	650	
			$3.0\text{V} \leq V_O \leq 5.0\text{V}$	—	360	500	
ΔV_{LINE}	Line Regulation	$V_{OUT}+1.0\text{V} \leq V_{IN} \leq 8.0\text{V}$	—	0.2	0.3	%/V	
I_{LIM}	Current Limit (Note3)	$\Delta V_{OUT}=10\%$	500	—	—	mA	
$\frac{\Delta V_{OUT}}{\Delta T_a}$	Temperature Coefficient	$-40^{\circ}\text{C} < T_a < 85^{\circ}\text{C}$	—	± 0.8	—	mV/ $^{\circ}\text{C}$	

- Note:
1. Load regulation is measured at a constant junction temperature, using pulse testing with a low ON time and is guaranteed up to the maximum power dissipation. Power dissipation is determined by the input/output differential voltage and the output current. Guaranteed maximum power dissipation will not be available over the full input/output range. The maximum allowable power dissipation at any ambient temperature is $P_D = (T_{J(MAX)} - T_a) / \theta_{JA}$.
 2. Dropout voltage is defined as the input voltage minus the output voltage that produces a 2% change in the output voltage from the value at $V_{IN} = V_{OUT} + 1\text{V}$ with a fixed load.
 3. Current limit is measured by pulsing for a short time.

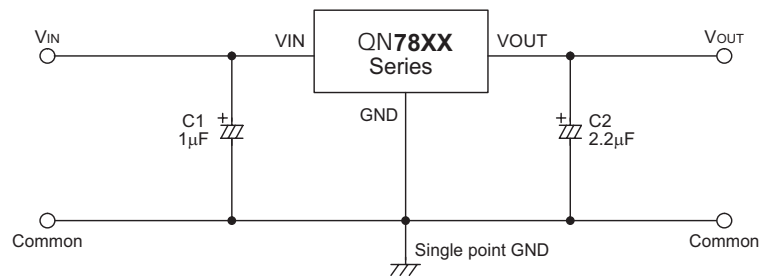
Application Circuits
Basic Circuits

Typical Application Circuits

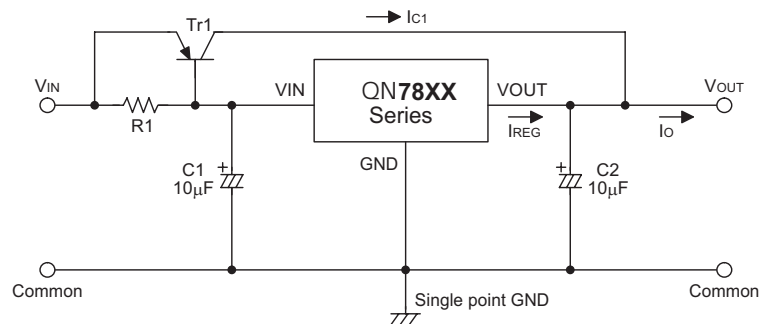
- High output current positive voltage regulator



$$R_1 = \frac{V_{BE1}}{I_{REG} - \frac{I_{C1}}{(1+\beta)}}$$

$$I_O = I_{C1} + I_{REG}$$

- Increased Output voltage Circuit

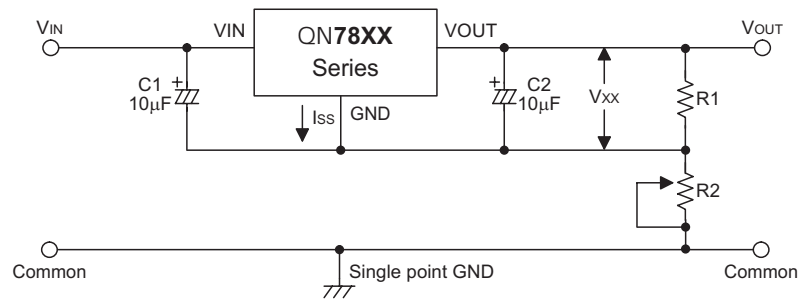

$$V_{OUT} = V_{xx} \left(1 + \frac{R_2}{R_1}\right) + I_{ss} R_2$$

- Dual Supply Circuit

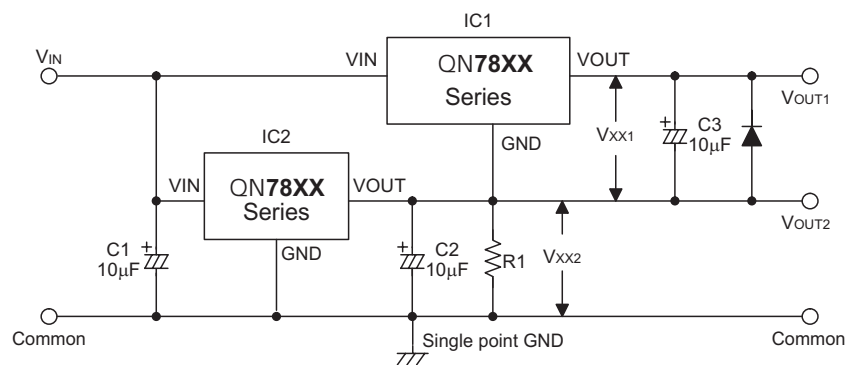

$$V_{OUT1} = V_{xx2} + V_{xx1}$$

$$V_{OUT2} = V_{xx2}$$

- Tracking Voltage Regulator

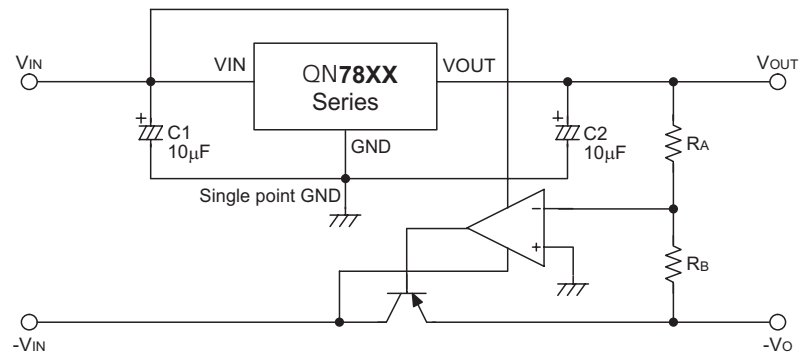

$$-V_o = V_o \times \frac{R_A}{R_B}$$

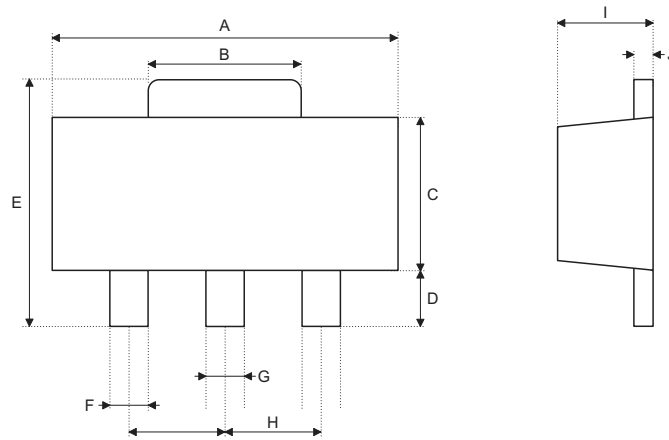
Package Information
3-Pin SOT-89 Outline Dimensions

Symbol	Dimensions in mil		
	Min.	Nom.	Max.
A	173	—	181
B	64	—	72
C	90	—	102
D	35	—	47
E	155	—	167
F	14	—	19
G	17	—	22
H	—	59	—
I	55	—	63
J	14	—	17

3-Pin TO-92 Outline Dimensions

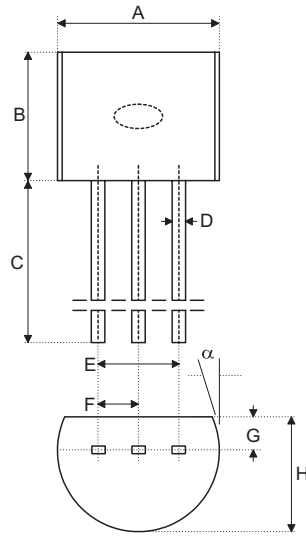

Symbol	Dimensions in mil		
	Min.	Nom.	Max.
A	170	—	200
B	170	—	200
C	500	—	—
D	11	—	20
E	90	—	110
F	45	—	55
G	45	—	65
H	130	—	160
I	8	—	18
α	4°	—	6°

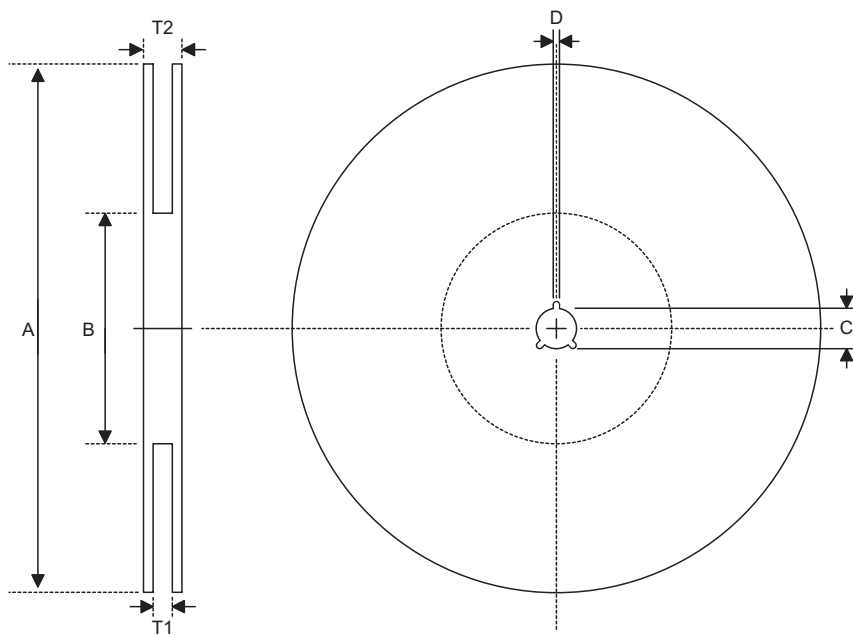
Product Tape and Reel Specifications
Reel Dimensions

SOT-89

Symbol	Description	Dimensions in mm
A	Reel Outer Diameter	180±1.0
B	Reel Inner Diameter	62±1.5
C	Spindle Hole Diameter	12.75+0.15
D	Key Slit Width	1.9±0.15
T1	Space Between Flange	12.4+0.2
T2	Reel Thickness	17-0.4

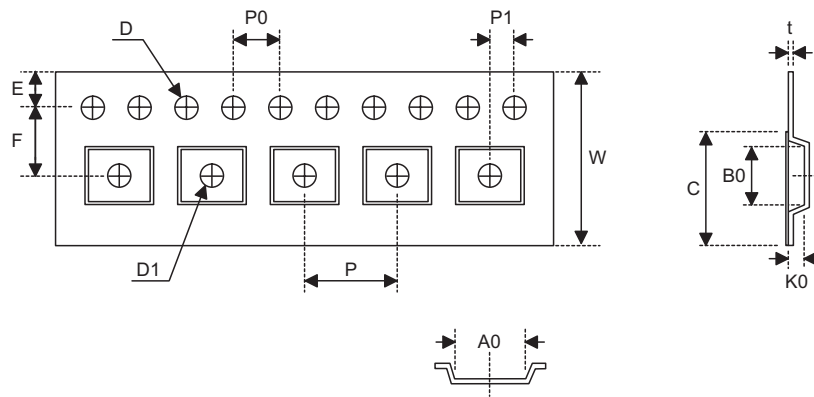
Carrier Tape Dimensions

SOT-89

Symbol	Description	Dimensions in mm
W	Carrier Tape Width	12.0+0.3 -0.1
P	Cavity Pitch	8.0±0.1
E	Perforation Position	1.75±0.1
F	Cavity to Perforation (Width Direction)	5.5±0.05
D	Perforation Diameter	1.5±0.1
D1	Cavity Hole Diameter	1.5±0.1
P0	Perforation Pitch	4.0±0.1
P1	Cavity to Perforation (Length Direction)	2.0±0.10
A0	Cavity Length	4.8±0.1
B0	Cavity Width	4.5±0.1
K0	Cavity Depth	1.8±0.1
t	Carrier Tape Thickness	0.30±0.013
C	Cover Tape Width	9.3

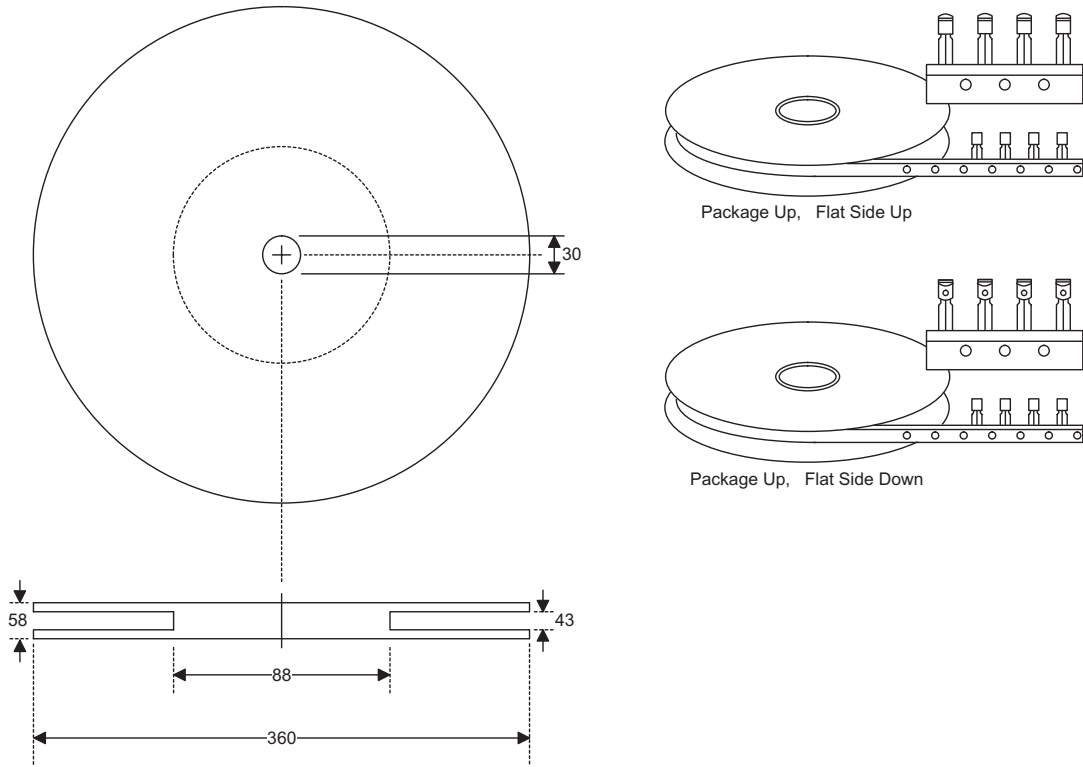
TO-92 Reel Dimensions (Unit: mm)

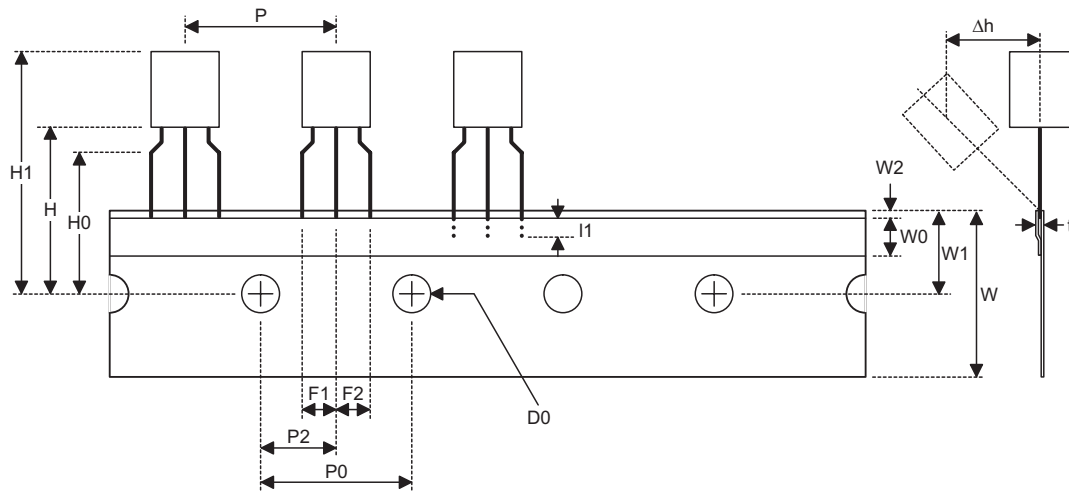

TO-92 Carrier Tape Dimensions

TO-92

Symbol	Description	Dimensions in mm
l1	Taped Lead Length	(2.5)
P	Component Pitch	12.7±1.0
P ₀	Perforation Pitch	12.7±0.3
P ₂	Component to Perforation (Length Direction)	6.35±0.4
F ₁	Lead Spread	2.5+0.4 -0.1
F ₂	Lead Spread	2.5+0.4 -0.1
Δh	Component Alignment	0±0.1
W	Carrier Tape Width	18.0+1.0 -0.5
W ₀	Hold-down Tape Width	6.0±0.5
W ₁	Perforation Position	9.0±0.5
W ₂	Hold-down Tape Position	(0.5)
H ₀	Lead Clinch Height	16.0±0.5
H ₁	Component Height	Less than 24.7
D ₀	Perforation Diameter	4.0±0.2
t	Taped Lead Thickness	0.7±0.2
H	Component Base Height	19.0±0.5

Note: Thickness less than 0.38±0.05mm~0.5mm

P₀ Accumulated pitch tolerance: ±1mm/20pitches.

() Bracketed figures are for consultation only